

RoHS Compliant & Pb Free Product

MC1-MI11A:

- Category: Mixer
- Device Package: MSOP-8 (Hittite)
- Cell Size: Single (1x1)
- PCB Material/Layer Details: RO4350/2 layer with thickness 0.020"

Supported Device Package and Its Pin Allocation:

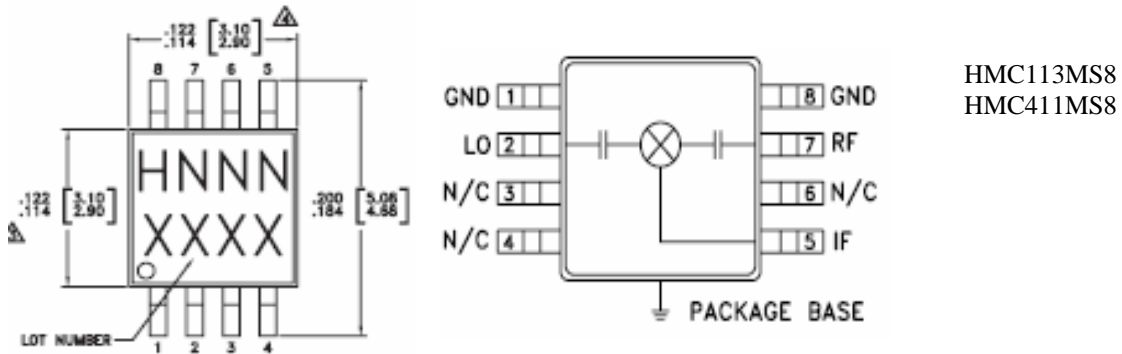

HMC113MS8
HMC411MS8

Schematic:

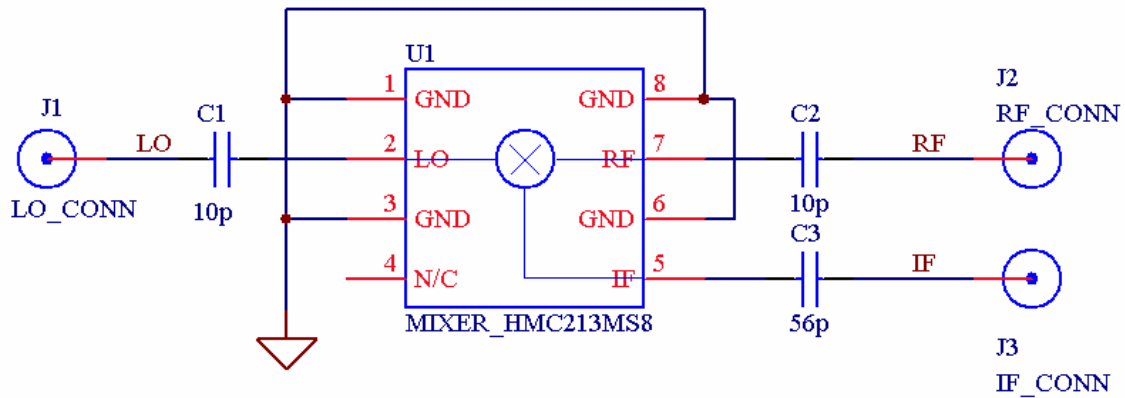

MC1-MI11A PCB Layout:

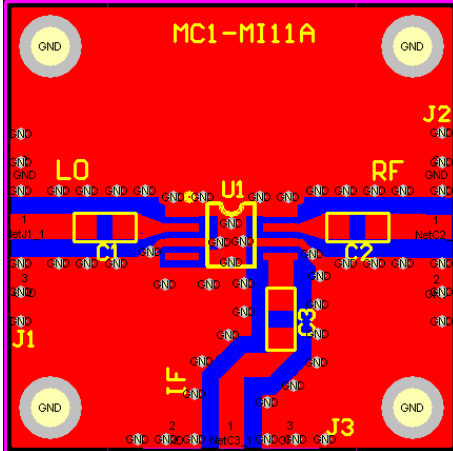

MC1-MI11A Assembly Drawing:

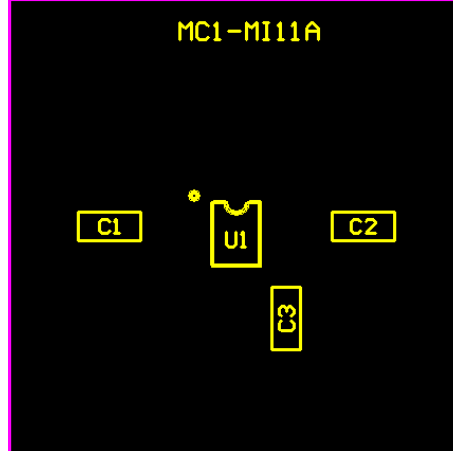

Minimum supported devices and its vendors:

<p>HITTITE</p> <p>HMC213MS8</p> <p>HMC411MS8</p>
--

Bill of Material Example:

Used	Part Type	Designator	Footprint
2	10p	C1 C2	0603
1	56p	C3	0603
1	MIXER_HMC213MS8	U1	MSOP-8