

RoHS Compliant & Pb Free Product

MC1-MI13A:

- Category: Mixer
- Device Package: MSOP-8G (Hittite)
- Cell Size: Single (1x1)
- PCB Material/Layer Details: RO4350/4 layer with thickness 0.030”

Supported Device Package and Its Pin Allocation:

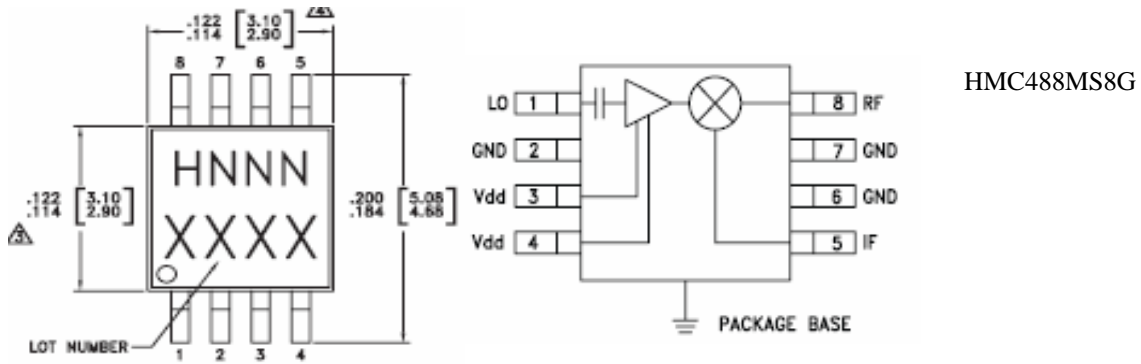

Schematic:

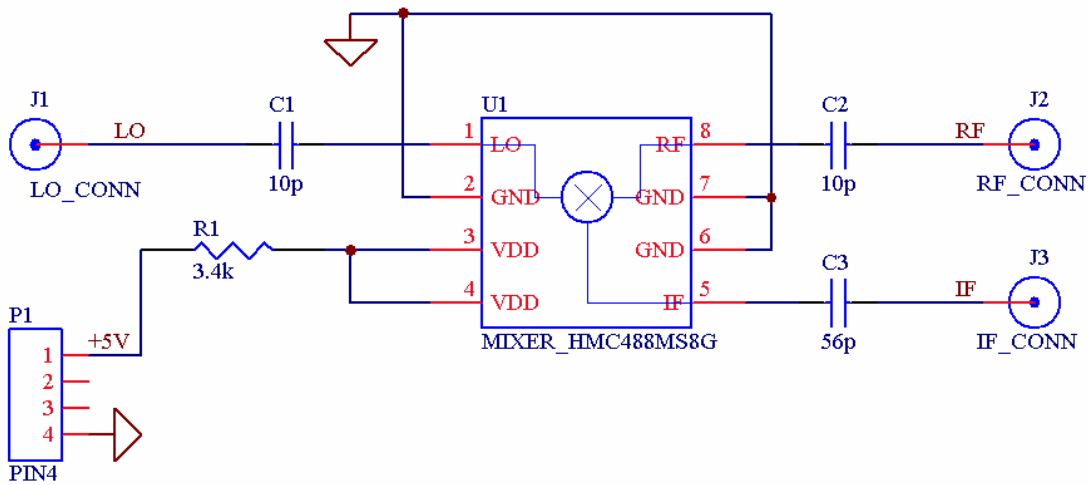

MC1-MI13A PCB Layout:

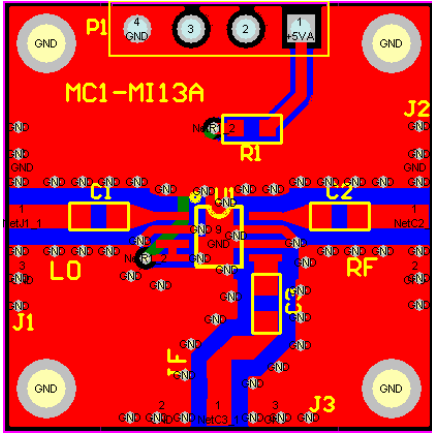

MC1-MI13A Assembly Drawing:

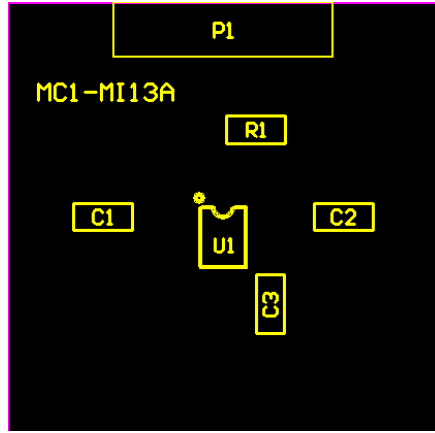

Minimum supported devices and its vendors:

Hittite: HMC488MS8G

Bill of Material Example:

Used	Part Type	Designator	Footprint
1	3.4k	R1	0603
2	10p	C1 C2	0603
1	56p	C3	0603
1	MIXER_HMC488MS8G	U1	MS8G
1	PIN4	P1	P2_CON4_S